

Release Date: 09-2016

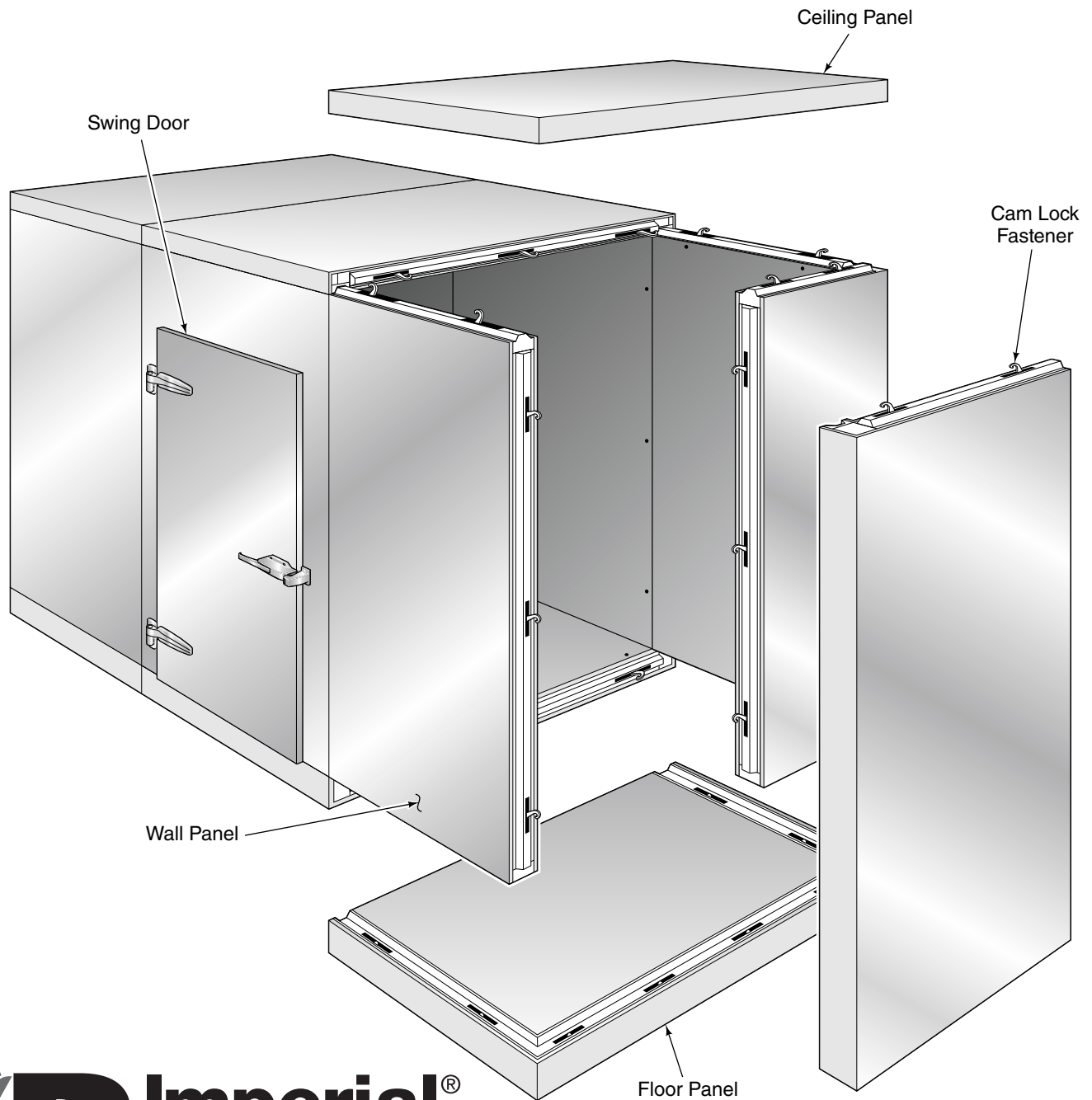

## Imperial Brown

*west coast facility*  
2271 NE 194th Avenue  
Portland, OR 97230  
Toll Free (800) 238-4093  
Local (503) 665-5539

*midwest facility*  
2015 W. Main St.  
Prague, Oklahoma 47864  
Toll Free (800) 289-2784  
Local (405) 567-1960

*east coast facility*  
209 Long Meadow Drive  
Salisbury, NC 28147  
Toll Free (800) 438-2316  
Local (704) 636-5131

## Table of Contents

	Page
Important Things You Should Know .....	4-5
Shipping and Packaging .....	4
Product Storage .....	4
Permits and Engineering .....	4
Electrical Requirements .....	4
Inside Safety Release .....	4
Ceiling or Roof Loads .....	5
Structural Engineering and Seismic Restraint .....	5
Construction Details .....	5
Penetrations .....	5
Installation Over Fresh Concrete .....	5
Installation Next To Existing Buildings .....	5
Installation Outside .....	5
Installation Above Ground .....	5
Service Hot Line .....	5
Getting Started .....	6
Tools Required .....	6
Locate the Parts Box .....	6
Shop Prints .....	6
Shipping List .....	7
Cam Lock Fasteners .....	7
Assembling Panels Together .....	8
Floor Installation .....	9
Prefabricated Insulated Floors .....	9
Insulated Pit Floors .....	11
Wall Panel Preparation .....	13
Installing the Wall Panels .....	15
Installing the Ceiling Panels .....	16
Lag-Down Ceilings .....	16
Cam Lock Ceilings .....	17
Doors and Other Add-On Items .....	18
Swing Doors with Flat Frames .....	18
Horizontal Sliding Doors .....	18
Vertical Lift Doors .....	18
Traffic Doors .....	19
Glass Doors and Windows .....	19
Strip Curtain and Flexible Doors .....	19
Shelving .....	19
Finish Work .....	20
Snap Caps .....	20
Tie-Downs and Cove Base .....	20
Door Angles .....	20
Wainscoting .....	20
Finish Caulk .....	20
Ceiling Trim .....	20
Refrigeration Installation .....	21
Periodic Maintenance .....	22
Troubleshooting .....	23

## IMPORTANT

1. Read all instructions!
2. Please review all illustrations and Shop Prints before installing the structure.
3. Manuals for third-party equipment, such as refrigeration or alarm devices, are included with each item. If an item is pre-mounted on the Walk-In, the item documentation is included with the Walk-In information package. The latest Imperial Brown Cooler and Freezer Manual can be found at <http://imperial-brown.com>.
4. Inspect and report any damage and/or missing parts, before installing. Imperial Brown will not be responsible for costs of installing or removing damaged parts.

### Warnings and Cautions

We provide many important safety messages in this manual about your Walk-In. Always read and obey all safety messages.



This is the safety alert symbol.

This symbol alerts you to potential hazards that can kill, injure, or damage equipment.

All safety messages will follow the safety alert symbol and either the word “Warning” or “Caution.”

These words mean:



**WARNING** You can be killed or seriously injured if you don't follow instructions.

**CAUTION** Equipment can be damaged or destroyed if you don't follow instructions.

### Important Safety Instruction—Read Prior to Installation

All safety messages will tell you how to proceed to reduce the chance of death, injury, or damage to the Walk-In.

To reduce the risk of fire, electrical shock, injury, death, or damage when installing or repairing a Walk-In, follow basic precautions, including the following:

 **WARNING:** During installation, make sure that equipment does not exceed floor rating. Note that floor rating might be less than finished product rating until floor installation is complete (for example, until wear surface is field installed). Plywood sheeting should be used to spread the load.

 **WARNING:** Remove children and unnecessary adults from the area when installing or servicing the Walk-In.

 **WARNING:** Panel lifting methods and panel lifting equipment must meet OSHA approved guidelines for the designed loads and lifting methods intended.

 **WARNING:** Temporary support of panels during assembly is the responsibility of the general contractor or the onsite installation contractor. Temporary support should only be attempted by trained individuals familiar with the safest methods possible for securing loose or otherwise unsupported panels. Stacking, leaning or blocking of panels when not permanently supported may result in hazardous conditions. Personnel injury or panel damage may result.

 **WARNING:** Walking, climbing, or standing on non-permanently supported panels may result in hazardous conditions including falling. Personnel injury or panel damage may result.

 **WARNING:** Improper wiring or lack of proper ground can result in fire, electrical shock, injury or death. Disconnect power to the Walk-In before performing any electrical repairs. Field wiring or electrical repair should be done by a licensed professional electrician. Follow all local building codes and laws for electrical installation.

 **WARNING:** In case of electrical fire, disconnect the power supply. Do not use water on electrical fires. Smother the fire with an extinguisher rated for C-class fires.

 **CAUTION:** Per NEC 300-7, all raceways passing from different temperatures shall be sealed with putty or other method to stop the travel of moisture. Furthermore, all junction box cover plates shall be sealed. Verify these seals are in place and functioning properly after performing any service on the unit.

## Important Things You Should Know

### Shipping and Packaging

Upon receiving freight, check the bill of lading for the correct number of pallets and check the product for any shipping damage. Take photos of damaged goods. Report issues to both the trucking company and Imperial Brown, Inc. Contact the freight company directly, at time of delivery, to file a claim.

### Product Storage

If panels are to be stored for any length of time before installation, make sure that they are protected from moisture, sunlight, and temperature extremes. Exposure to sunlight or excessive temperature will make protective plastic sheeting difficult to remove and labels may dry out and peel off. Moisture trapped between panels can cause corrosion, such as white rust.

### Permits and Engineering

Imperial Brown is not responsible for obtaining any permit, unless otherwise noted on the Sales Order. Specific local building code, engineering, or regulatory requirements are to be communicated to Imperial Brown when placing the order.

### Electrical Requirements

Electrical requirements for each electrical component are identified on the Shop Print. Component instructions and electrical wiring information for specific components is supplied along with each component. Component instructions may also be found online by searching for the component brand and model number.

### Inside Safety Release

Check to make sure the inside safety release on the door works correctly and that all personnel understand how to use it.

**Swing Doors**—All swing doors equipped with a positive latch or lockable non-positive latch include an inside safety release mechanism. The safety release allows an occupant to open a latched or locked door from the inside. Push or turn the knob to release the door. Follow the directions printed on the safety release label. This includes padlock hasps and full-width removable locking bars.

**Sliding Doors**—All electrically-driven doors have a Manual Release mechanism that allows the manual operation of the door. This can be used by turning the inside release handle to disconnect the door from the drive. The door can then be slid open and close.

**Sliding Door with Padlock Hasp**—Sliding doors equipped with padlock hasp locking devices have an inside release knob. Turn the knob to unscrew the lock hasp system from the wall, in order to let the door open.

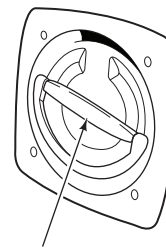
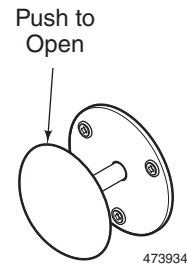

Turn to Release Door.  
Slide Door Open.

Swing Doors

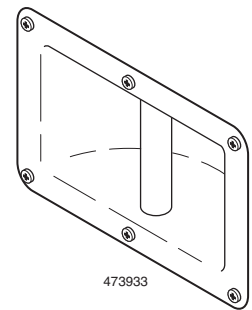

Sliding Doors



Unscrew Knob. Pull Out.  
Slide Door Open.

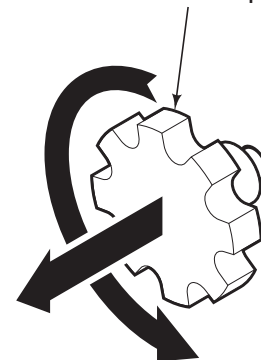

Doors with padlock hasp or deadbolt locking device

## Important Things You Should Know

### Ceiling or Roof Loads

Each unit is designed to meet certain intended loads. Specific load rating for each unit is indicated on the Shop Print.

**Live Loads**—Limit number of workers on ceiling. Workers should be evenly spread out across the ceiling. Maintain perimeter loading in lieu of center (mid-span) loading whenever possible. Do not exceed maximum loading (*see Shop Print*).

**Environmental Loads**—Outdoor Walk-Ins are designed for specific environmental loads like snow loads, wind loads, etc. Walk-In must be installed at its intended location or environmental load requirements might not be met.

**Equipment Loads**—The Imperial Brown Design Department requires review of all equipment, including refrigeration, fire sprinkler, air handling, and others, before it is installed or attached to ceiling panels. Failure to submit a list of equipment for review will void any warranty and may lead to structure failure.

### Construction Details

Tie-downs, hold-downs and other requirements must be installed or performed exactly as shown in the Shop Print, with no substitutions for fastener size, spacing or embedment. Variations require permission of the Imperial Brown Design Department.

### Penetrations

Be aware that electrical or mechanical penetrations through the Walk-In may need to be addressed as the Walk-In is being erected, prior to losing access to these items.

### Installation Over Fresh Concrete

Out-gassing from curing concrete may cause damage to the metal finish. To avoid, ensure proper ventilation (i.e. an open door).

### Installation Next To Existing Walls

Two inches of clearance is recommended for air flow and to allow for wall surface irregularity.

### Installation Outside

**Design Loads**—These units are designed for wind load, snow load, and snow drift. Erecting another structure near the unit location may affect the load requirements, as loads and drifts may change.

**Drainage**—Make sure that rain drains away from the unit.

### Installation Above Ground

Installing a unit above ground, such as on the second story of a building, always requires an insulated floor. See Floor Installation.

### Service Hot Line

**800.238.4093**

## Getting Started

### Tools Required

Minimum required tool set includes:

- Tape measure
- Construction hammer
- Chalk line
- Drill and electric screwdriver
- Pry-bar
- Carpenters bubble level
- Caulking gun
- Cam lock wrench (provided)
- Tin snips

### Locate the Parts Box

The parts box(es) is generally a cardboard box located in one of the pallets. It contains this Installation Instruction, the Shop Prints of the Walk-In, a Shipping List, and supplies such as fasteners, cam lock wrench and caulk.

### Shop Prints

Enclosed with the unit is a Shop Print showing proper location of all panels. Before placing any panel into position, check the print for proper location.

**NOTE:** This *Installation Instruction Manual* is provided to make the installation process as easy as possible, but it does not show every application available. Some illustrations and details may not apply to your unit. Please note any differences between the unit illustrated and your actual unit.

Make sure that you understand the prints, notes, and details in the Shop Prints (Parts Box) before beginning. See *Table 1*.

Identifying marks appear on all panels. These marks guide the installer to the proper location for each individual panel. See *Figure 1* and *Table 2*.

Panels with the same part number (See *Figure 1*) can be interchanged.

Symbol	Meaning
AFF	Above Floor Finish
BKG	Backing
CL	Centerline
DC	Double Cam
DP	Double Pin
HIC	Height In Clear (clear/finished opening height)
ID	Inside Dimension
MCA	Maximum Current Amperage
MOPD	Maximum Overage Protection Device (Circuit Breaker)
NBI	Not By Imperial Brown
NIC	Not In Contract
NTS	Not To Scale
O/C	On Center
OD	Outside Dimension
RC	Reverse Cam
SIM.	Similar
SPL	Special (panel has special features or non-standard cam/pin layout)
TYP	Typical
WIC	Width In Clear (clear/finished opening width)

**Table 1. Common Drawing Abbreviations on Shop Print**

Symbol	Meaning
W1	Wall panel #1
C1	Ceiling panel #1
F1	Floor panel #1
S1	Screed panel #1
U1	Floor Spline #1
[A]	Door or opening [A]
V1.A	Valance #1 above opening [A] A valance panel goes above a window or an opening. Valance layout is best shown on elevation views.
B1.A	Base #1 below opening [A] A base panel goes below a window or an opening. Base layout is best shown on elevation views.
T	Thermometer
\$	Single-pole switch
\$ <sub>3</sub>	3-way switch
\$ <sub>4</sub>	4-way switch

**Table 2. Sample Panel Numbers**

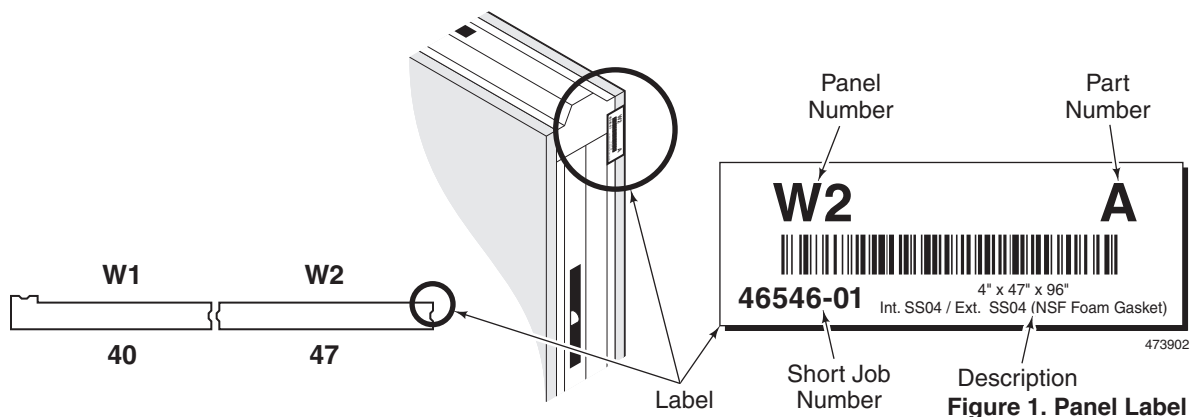

**Figure 1. Panel Label**

## Shipping List

The Shipping List included in the Parts Box identifies every item shipped and indicates in what parcel (pallet or box) it is located. It also indicates if a parcel is located in another parcel (for example, the Parts Box being in a pallet).

Panels are stacked in the best way possible to minimize the risk of shipment damage. They are not stacked in order of panel numbers. Use the Shipping List to easily locate panels and hardware.

## Cam Lock Fasteners

Panels are joined, using a 3/8" hex wrench (supplied) on a cam lock device. Imperial Brown cam lock fasteners must be fully understood before assembling prefabricated panels. All cam locks must be in the Open position before placing panels together. Fasten the cam locks as follows:

1. With the cam locks of the first panel in the fully Open position, place the second panel into position.

It should be tight along the matig surface and flush at the edges. See *Figure 2*.

2. Turn the cam lock clockwise 1/4 turn until the lock is engaged with the hinging pin. Do not tighten yet. See *Figure 3*.

3. Check that the panels are still tight and properly aligned, then turn the cam lock 1/2 turn to the fully locked position. This will draw the panels tightly together. Install cam hole covers. See *Figure 4*.

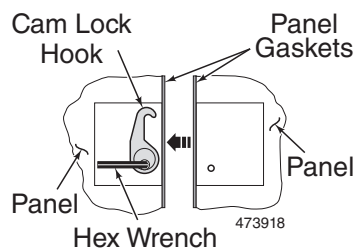

**Figure 2. Open Position**

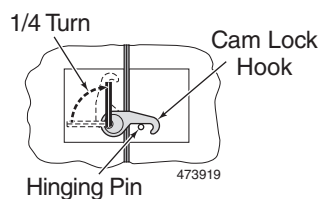

**Figure 3. Engaged Position**

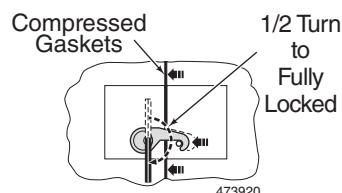

**Figure 4. Locked Position**

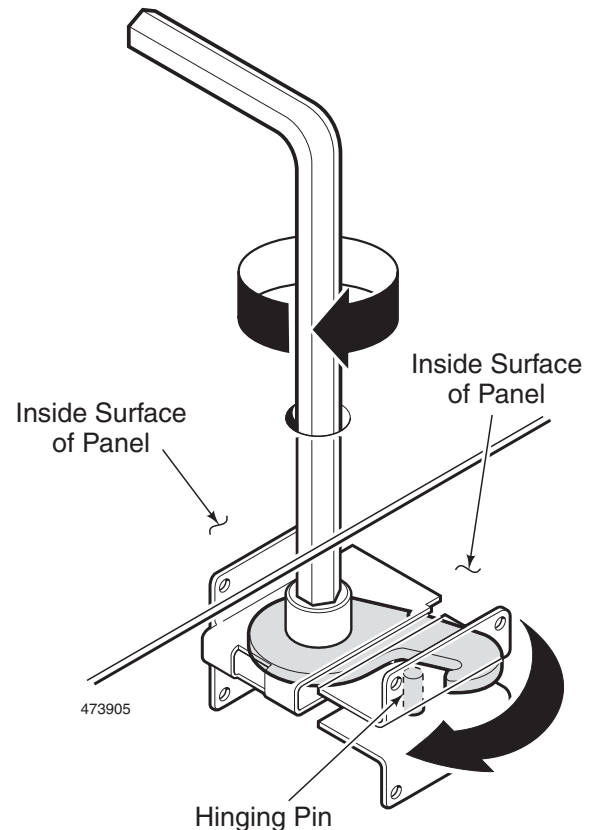
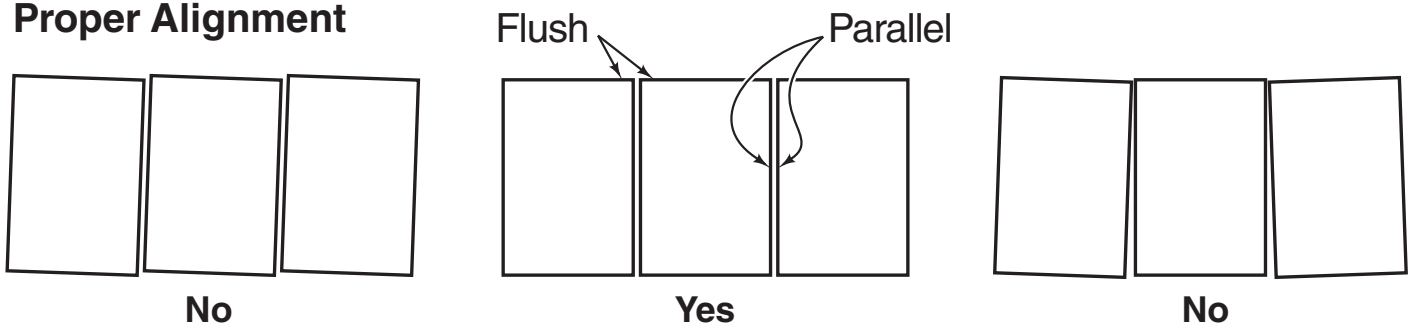

**Figure 5. Cam Lock Fastener**

### Assembling Panels Together

Panel widths are shown along each panel on the plan views. See the Shop Print. Standard joint width is 1/16" between panels. This width may be different for certain special joint types. Verify actual joint size on the Shop Print. When fastening panels together, be certain that dimensions are respected. For example, irregular or loose tightening of the cam locks may cause overall wall width to increase. See Figure 6.

#### Proper Alignment



#### Proper Joint Size

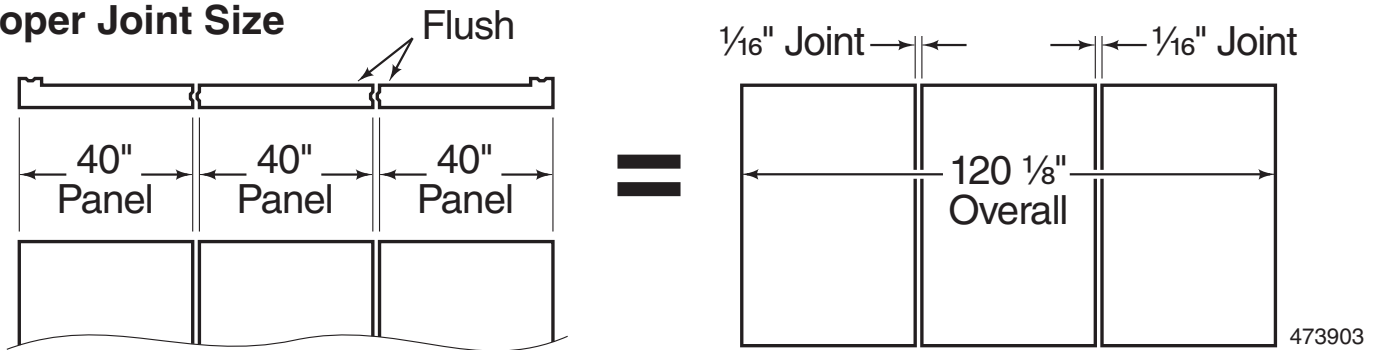

Figure 6. Assembling Panels



## Floor Installation

Depending on the application, the walk-in unit may be supplied with, or without, floor panels. Refer to the Shop Prints to identify what floor system is used, if any. Floor types described here include Prefabricated Insulated Floors and Insulated Pit Floors.



**WARNING:** If the unit is installed above another room, make sure the existing floor load rating is sufficient to support the Walk-In and its product. Also, make sure to seal the floor.

### Prefabricated Insulated Floors

Outline the perimeter of the Walk-In with a chalk line on the installation surface. Find the high point of this area. The entire floor area must be leveled from this highest point. Floor leveling can be done with wooden supports and shims.

**IMPORTANT:** A level surface is critical. If the floor is not level, vertical panels cannot be aligned properly. If the floor system includes optional sleeper strips, lay provided strips perpendicular to the prefabricated floor panels (across floor panel joints), spaced as indicated on the Shop Prints. See Figure 7.

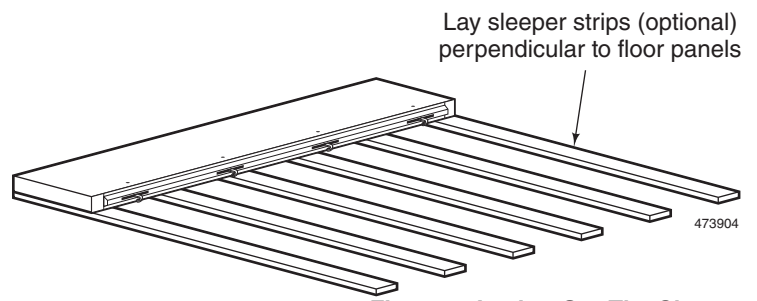

Figure 7. Laying Out The Sleepers

Before cam locking, place a bead of butyl caulking between each floor panel. Flush the top and end of each panel to ensure that the panels themselves are level. See Figure 8.

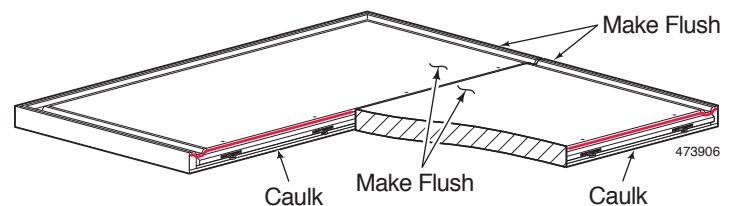

Figure 8. Caulk and Flush

Do not install the floor panels one row or column at a time. Instead, install the floor panels in both directions. See Figure 9.

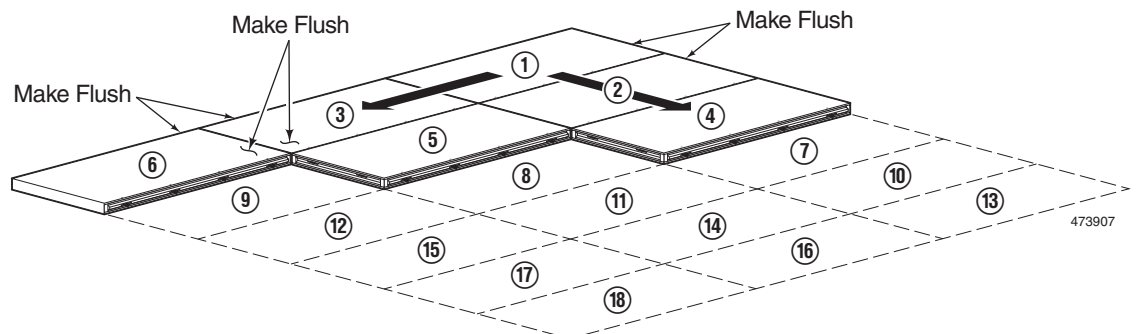

Figure 9. Panel Assembly Sequence

Verify that row and column dimensions grow, as indicated on the Shop Print, accounting for the joints. Measure to be certain that all panel runs remain square. See Figures 6 and 10.

**NOTE:** Some installations require fastening down the floor panels. Check the Shop Print for information.

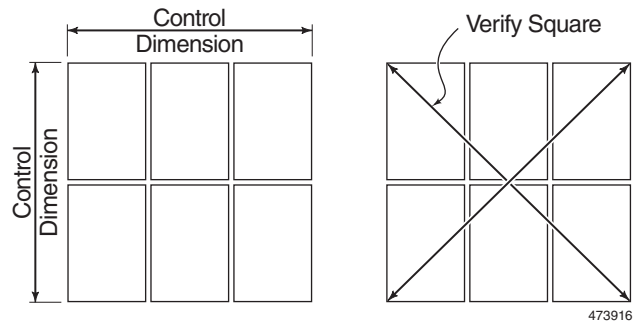

Figure 10. Measure for square layout

**Heavy Duty Floors** – Heavy duty floors may require the installation of diamond-tread wearsurface and plywood underlayment in the field. These are generally installed after the unit is erected. See construction details on Shop Prints. See Figure 11.

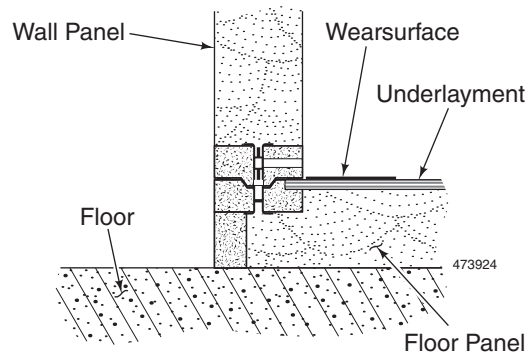

Figure 11. HD floors with diamond tread

**Installation below grade** – Floor panels may be installed recessed below grade. This allows for the inside and outside floors to be at the same elevation. In some cases, floor panels are recessed even deeper, to allow for a concrete slab to be poured above. See Figure 12.

Consult the Shop Prints for exact model, layout, dimensions and details.

**NOTE:** If the unit requires floor tie-downs, they should be installed at this stage prior to pouring concrete.

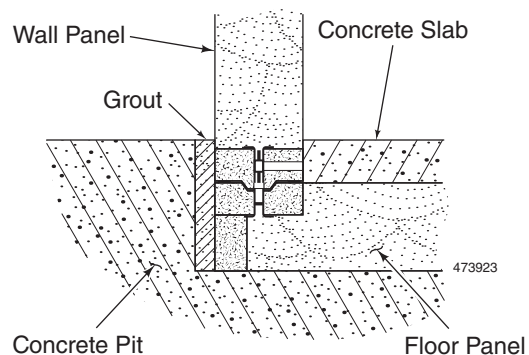

Figure 12. Installation Below Grade

## Insulated Pit Floors

### Wall Panels Above Grade

The floor is insulated using board stock urethane. Imperial Brown may, or may not, provide the materials. The pit floor thermal break must be located under the wall panels. Make sure that the actual pit floor dimensions match the requirements shown in the Shop Prints. Pay close attention to the door area details. See Figure 13.

**NOTE:** An Insulated Pit Plan, in the Shop Print, is provided to indicate the thermal break and door notch size and location. A qualified professional engineer familiar with cold-storage design and the end user's site conditions and application should design the pit depth, concrete floor above and below insulation, design, reinforcement, thickness and construction of concrete. See project contract documents. All concrete and excavation work and design is by others.

**NOTE:** Information provided here is conceptual only. Consult the Shop Prints and a qualified professional engineer for pit design and concrete requirements.

1. Apply asphalt emulsion liberally and evenly to the bottom and sides of the concrete pit.
2. Apply overlapping layers of vapor barrier to the entire coated area. Overlap seams 3" minimum and seal seams with asphalt emulsion. Vapor barrier should extend 3" above the top of the recess or finish floor.
3. Apply the first layer of stock board urethane insulation sheet inside of the vapor barrier. Cut to fit as needed.
4. Apply the second layer with sheets positioned perpendicular to the first layer sheets. Cut to fit and overlap all seams of the sheets below.
5. Install thermal break lumber to all sides of the recess, inside of the vapor barrier. Position the top of the lumber flush with the surrounding finish floor at grade. Fill any gap under the thermal break.
6. Apply a third layer of insulation, if applicable. Apply this layer with sheets positioned perpendicular to the second layer sheets. Overlap all seams completely. Cut to fit as needed.
7. Install felt paper over the last layer of insulation sheets (optional). Cover insulation and thermal break lumber so that concrete cannot leak or escape beyond or below the felt paper.
8. Pour concrete in the remaining cavity to flush with the thermal break and outside floor.

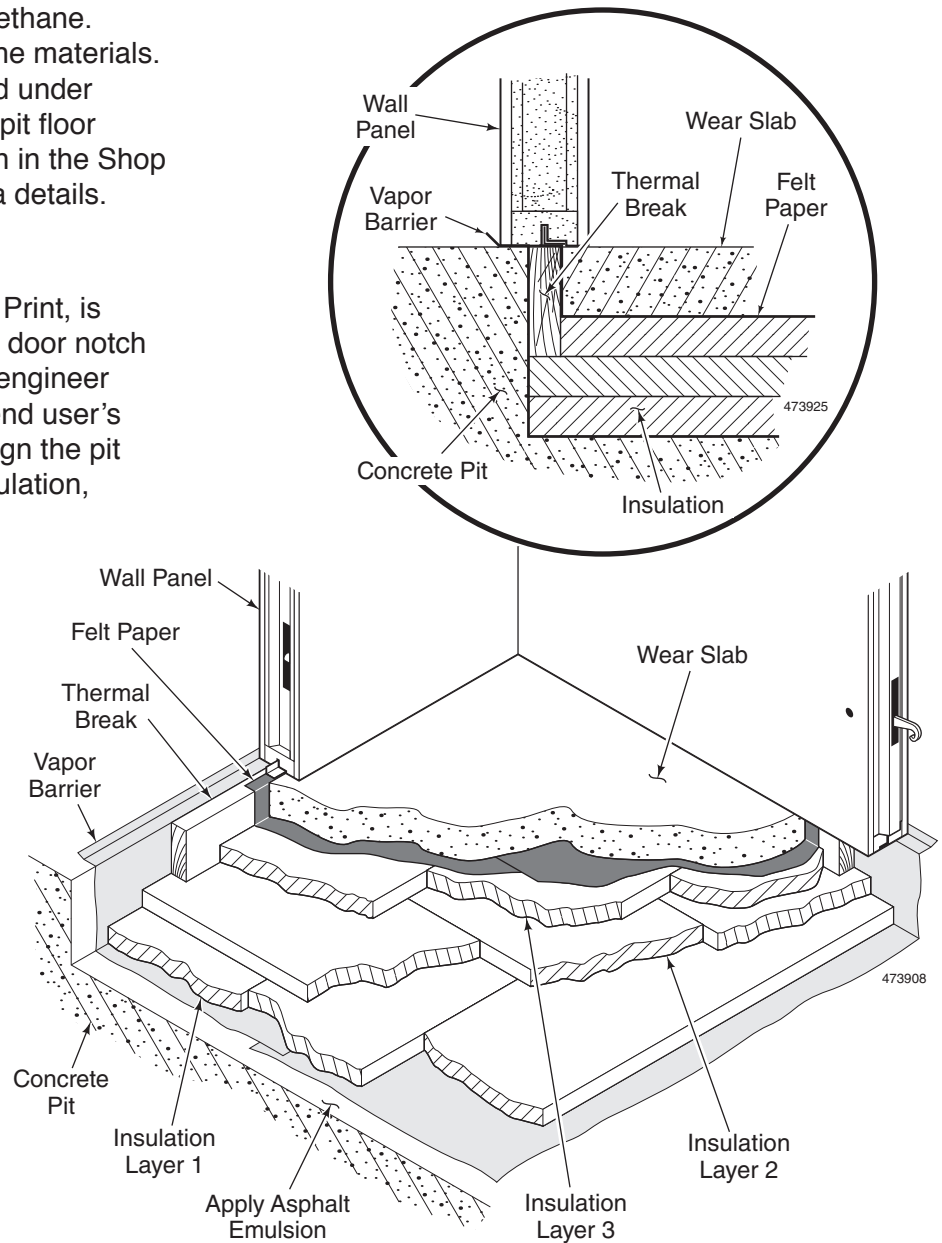

Figure 13. Insulated Pit with Wall Panels Above Grade

### Wall Panels Below Grade

In this situation, wall panels are installed inside the pit and layers of insulation are added afterward, between the wall panels. A layer of concrete is poured above the insulation to create the wear surface.

See Figure 14.

Consult the Shop Prints for exact model, layout, dimensions and details.

**NOTE:** Information provided here is conceptual only. Consult the Shop Prints and a qualified professional engineer for pit design and concrete requirements.

1. Apply asphalt emulsion liberally and evenly to the bottom and sides of the concrete pit.
2. Install the appropriate floor screed and wall panel, as described in sections *Floor Connection System* and *Installing the Wall Panels*.
3. Apply overlapping layers of vapor barrier inside the wall panel perimeter and over the coated area. Overlap seams 3" minimum and seal seams with asphalt emulsion. Vapor barrier should extend 3" above the top of the recess or finish floor.
4. Apply the first layer of stock board urethane insulation sheet inside of the vapor barrier. Cut to fit as needed.
5. Apply the second layer with sheets positioned perpendicular to the first layer sheets. Cut to fit and overlap all seams of the sheets below. Apply third layer, if applicable.
6. Install felt paper over last layer of insulation sheets. Extend the edges up to the vapor barrier and cover insulation so that the concrete cannot leak or escape beyond or below the felt paper.
7. Pour the concrete wear slab in the remaining cavity to flush with the outside floor.
8. Fill any gap between the wall panel and the edge of the pit with grout.

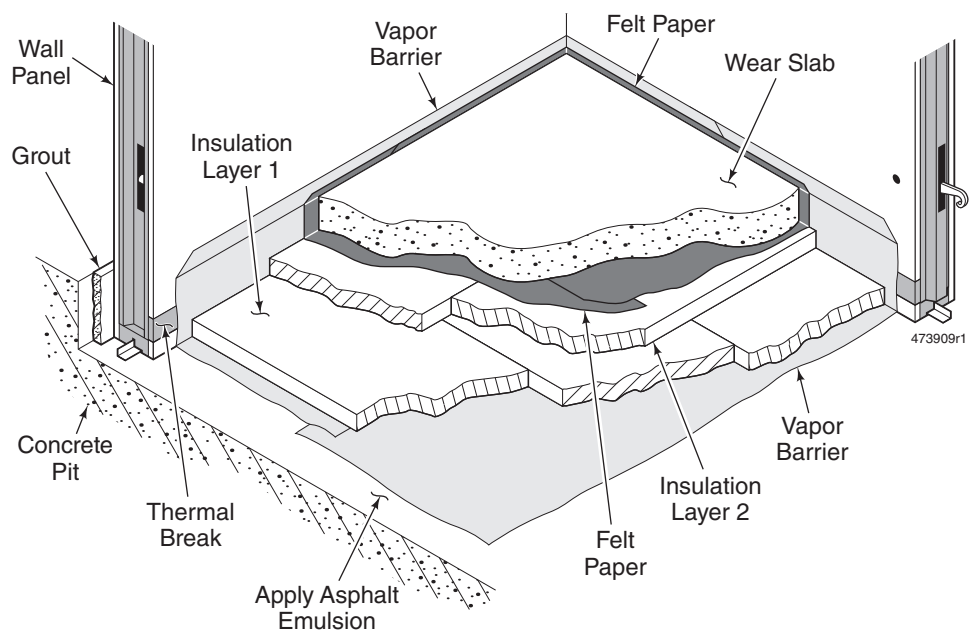
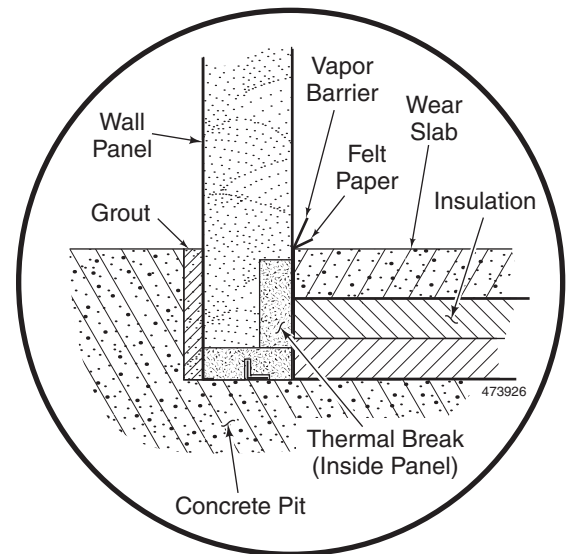

Figure 14. Insulated Pit with Wall Panels Below Grade

## Wall Panel Preparation

Walls panels may be installed on top of bare floor surface, insulated floor panels or curbs.

**NOTE:** Surface of installation must be level within 3/16" per 10'. Surface must be in good condition, solid, with no cracking.

### Outline

If the wall panels are not installed over an insulated panelized floor, trace the Walk-In exterior outline on the surface of installation. Check for square, by measuring diagonals. You may also check perpendicular angle using the 6/8/10 method. See Figure 15.

**Curbs** – If wall panels are to be installed on curbs, check that the curbs' dimensions and layout are correct, prior to starting installation. See *Shop Prints*.

**NOTE:** The Shop Print includes a curb plan that indicates curb cut widths and door opening locations. Curb layout and profiles are suggestions only. Curb and concrete floor design, reinforcement, thickness, and construction of concrete should be designed by a qualified professional engineer familiar with cold storage design and the end user's site conditions and application. See project contract documents. All concrete and excavation work and design is by others.

## Floor Connection System

The Shop Print indicates the type of wall-to-floor connection being used. Check the floor connections line under WALL PANELS. Five types are used: Angle Screed, Vinyl Track, Cam Lock Screeds, Legacy Floor Splines, and Cam Lock Floor Panel.

Prior to installing any wall panel, install the floor connection system provided with your Walk-In. Refer to the Getting Started section of this manual for information about Cam Lock Fasteners and Assembling Panels.

## Angle Screed

The angle screed is a 3/4" x 1" continuous piece of metal used to guide and line-up the wall panels.

The bottom of the wall panel has a groove designed to slip over the angle screed. Measure half the distance of the wall thickness and install the angle screed that far inside the Walk-In outline. Place the angle with its 1"-leg down, facing toward the inside of the Walk-In. Fasten the angle screed to the floor surface, holding the angle back approximately 1' from corners and openings. Angle screed fasteners are not provided and vary, depending on the installation substrate. Use a minimum of 4 fasteners per 8' section. See Figure 16.

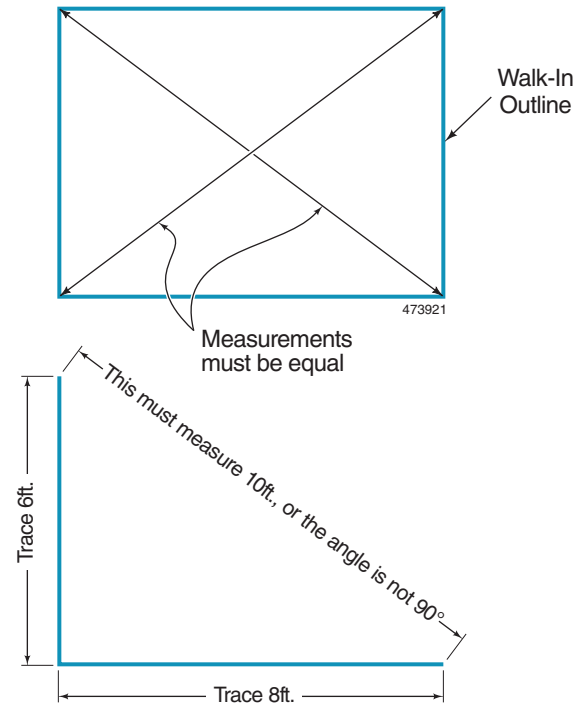

Figure 15. Verify Square Outline

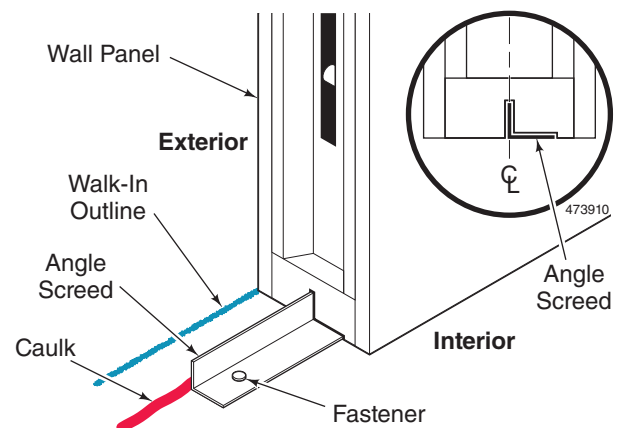
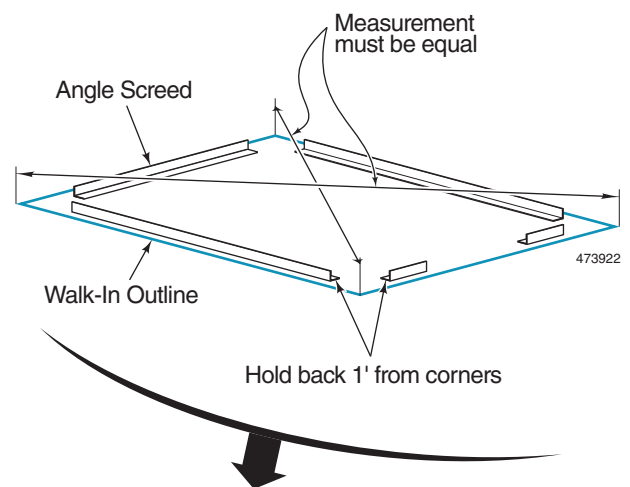

Figure 16. Angle Screed

## Vinyl Track

The vinyl track, a U-shape vinyl sleeve in which the wall panels sit, is used to guide and align the wall panels and provide an integrated NSF compliant cove base.

Install the vinyl screed slightly offset from the Walk-In outline so that the exterior side of the wall panel aligns with the outline. *See Figure 17.* Fasten the vinyl track, using the type of anchors and the spacing indicated on the Shop Prints. Miter the ends of the vinyl tracks at each corner, angle or T-panel, as necessary. Terminate the track at door openings and trim as needed. Apply one bead of butyl caulk under the vinyl track prior to fastening it down. *See Figure 17.*

## Cam Lock Floor Screed

The cam lock floor screed is a panel connector equipped with cam lock pins. Wall panels cam lock into it.

Install the cam lock screed by aligning its exterior side along the Walk-In outline. Follow the layout and fastening scheme indicated on the Shop Print. Apply a bead of butyl caulk under the screed prior to fastening it down. *See Figure 18.*

## Cam Lock Floor Panel

The cam lock floor panel is a prefabricated insulated floor system. Wall panels cam lock into it. Refer to the Floor Installation section for more information.

*NOTE: Some installations require fastening the floor panels down. Check the Shop Print for information.*

## Cam Lock Installation

All panels are connected with a mechanical Cam Lock, activated by using a hex wrench (included with your shipment). There are both male and female sections. The locks are foamed in place and securely anchored to provide a solid connection when the locking arm is tightened around the locking pin, located in the female section.

To operate the latch, insert the wrench through the access hole, located on the inside of each panel. Turn the wrench counter clockwise to full unlock and retrieve the locking arm. Pushing together the two panels you want to join, you will then turn the wrench ¼ turn clockwise. Continue to turn the wrench until you feel the panels lock together. You should feel the lock hit the stop position.

Some custom panels may have specialized lock locations. They will be marked. Follow the markings when connecting these panels.

Make sure that you have the panels in the correct and final position before locking, as continued locking and unlocking may result in less than satisfactory operation.

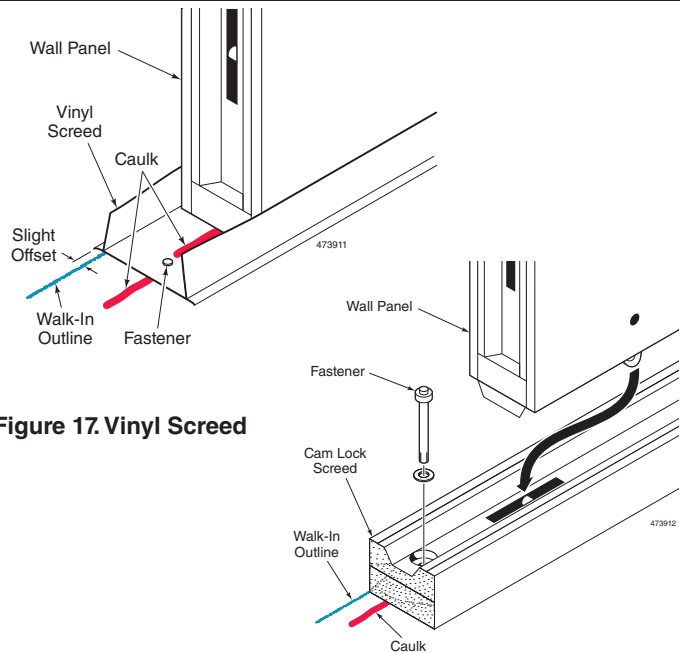

Figure 17. Vinyl Screed

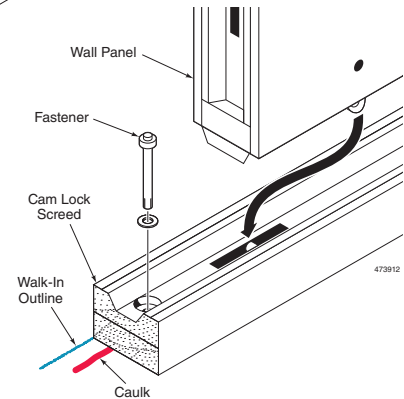

Figure 18. Cam Lock Screed

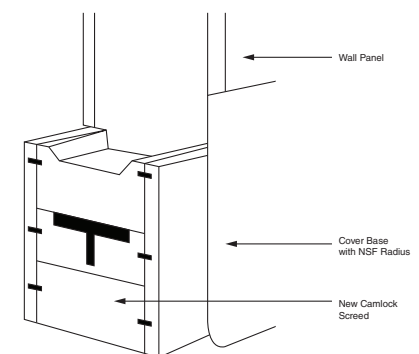

Figure 19. Floor Spline

## Floor Spline

Mark on the building floor the exact area the unit will occupy.

Lay out the spline as indicated on the spline layout drawing (*See Figure 19*) which is furnished with each unit. Each section is numbered and must be laid out as shown in order for the wall panels to lock down properly. Measure diagonally from corner to corner to be sure the floor spline is square.

The entire spline must be leveled from the highest point.

Determine where shims are needed for leveling, and cut them to the width of the spline. (Imperial Brown does not furnish these shims.)

Fasten the spline to the floor, using ramset studs, screws, expansion bolts, etc. (*See Figure 19*).

Seal all open areas between the spline and floor, using grout or butyl caulk.

Seal all joints between sections of spline, similarly to above.

Locate and install metal NSF cove base after walls are installed.

## Installing the Wall Panels

Wall panels are fastened to the floor, using one of five methods. The bottom edge of the wall panel must be:

- Inserted on top of angle screeds
- Inserted inside vinyl tracks
- Cam locked to cam lock screeds
- Cam locked to floor spline
- Cam locked to insulated floor panels

### Sealant

Place a heavy bead of butyl caulk on the outside of the angle screed (see Figure 16) or inside the vinyl track, cam lock screed or floor spline (see Figures 17, 18 or 19).

Apply enough caulk to prevent infiltration below the wall. Caulking is supplied at a rate of 1 tube per 8' of caulk.

### Wall Panels Placement

Install the wall panels, beginning with a corner panel. See Figure 20. Align the exterior of the wall panels with the edge of the floor panel, the Walk-In outline, or insert them in the screed or spline, depending on the wall panel anchor mechanism. In the case of cooler/freezer combos, it is generally preferable to install the freezer panels first.

**NOTE:** All cam locks must be in the Open position, before placing panels together. Refer to the *Getting Started* section of this manual for information about Cam Lock Fasteners and Assembling Panels.

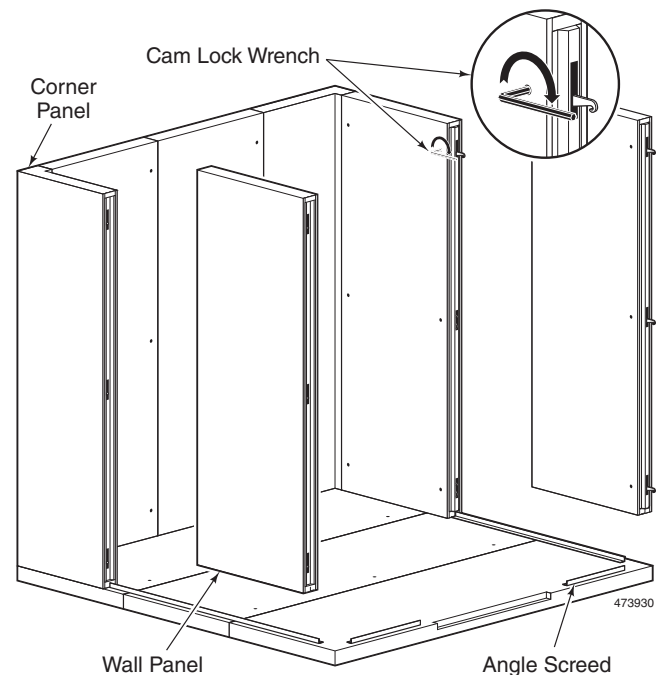

Figure 20. Installing Wall Panels

**CAUTION:** Each panel is numbered and must be installed in a specific location. The numbered location for each panel is shown on the Shop Prints. Even though two panels may look identical, they must not be swapped. They may be fitted with non-visible special features such as backing.

The panels may need to be shimmed, if the building floor has irregularities. Any gap between the wall and floor must be sealed.

**NOTE:** Door panels are assembled as any other wall panel. Door panels equipped with 4-sided heater cables or a heated threshold may require extra floor preparation (See Shop Prints).

The last wall panel to be installed should be the most accessible corner panel. (See Figure 21).

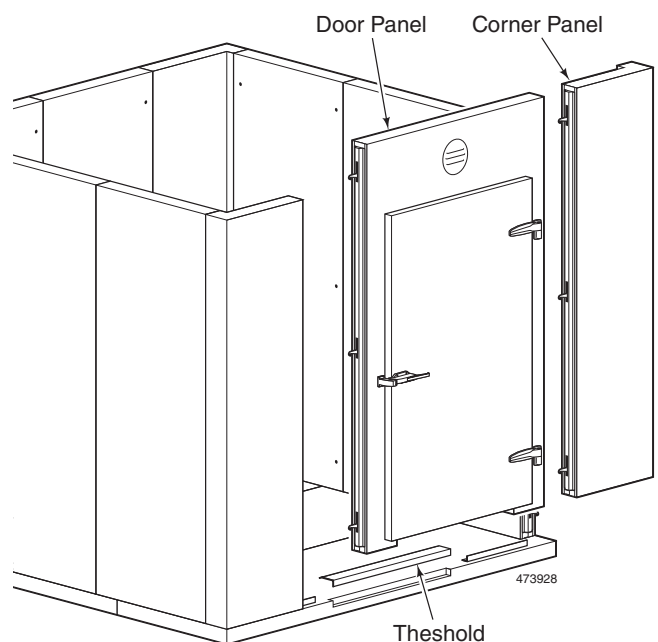

Figure 21. Completing Wall Panels Installation

### Installing the Ceiling Panels

Ceiling-to-wall connection can be either lag-down or cam lock. Check the Shop Prints for the type specified for your Walk-In. The ceiling may require support. Assembly details are provided in Shop Prints.

**CAUTION:** Temporary ceiling support may be necessary during installation.

See Figure 23.

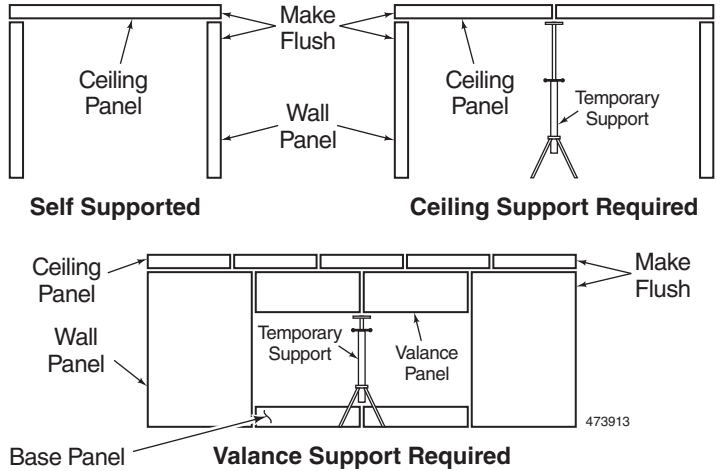

Figure 23. Support

It is recommended that the first ceiling panel be located above the door. As ceiling panels are cam locked together, make sure the ends of each panel are flush with one another. See Figure 24.

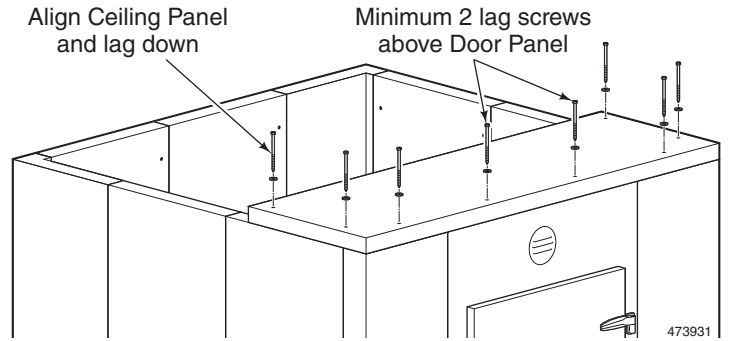

Figure 24. First Panel

### Lag-Down Ceilings

Ceiling panels connect to the walls using the hex head lag bolts and fender washers provided. Pre-drill pilot holes before driving the lag bolts through. Make sure that ceiling and wall panels are flush on the outside. Tighten the lag bolts enough to compress the gasket in the wall-to-ceiling joint. Do not over tighten the bolts. See Figure 25.

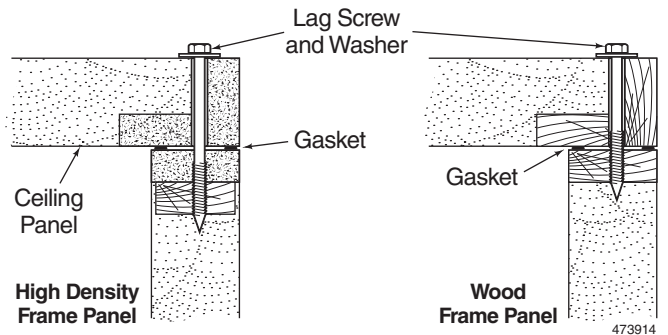

Figure 25. Ceiling to Wall Attachment (Lag-Down)

### Spline Blocks

Wood frame ceiling panels may require spline blocks installed at the joints to prevent panels from shifting out of plane. Joints requiring spline blocks are indicated on the Shop Print. Install a spline block in each cam lock slot. See Figure 26.

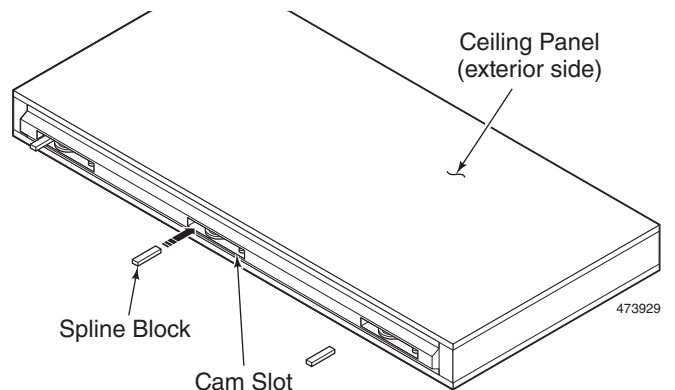

Figure 26. Spline Blocks



## Cam Lock Ceilings

The ceiling panels attach to the walls panels using the cam lock system. Refer to the *Getting Started* section of this manual for information about Cam Lock Fasteners.

**High-Density Frame and Soft Nose** ceiling panels have a groove that inserts over the wall panel tongue. This helps in aligning ceiling and wall panels. See *Figure 27*.

**Wood Frame** ceiling panels do not have a groove, nor do the wall panels have a tongue. Make sure the ceiling and wall panels are flush on the outside and square to each other, before tightening the cam locks. See *Figure 27*.

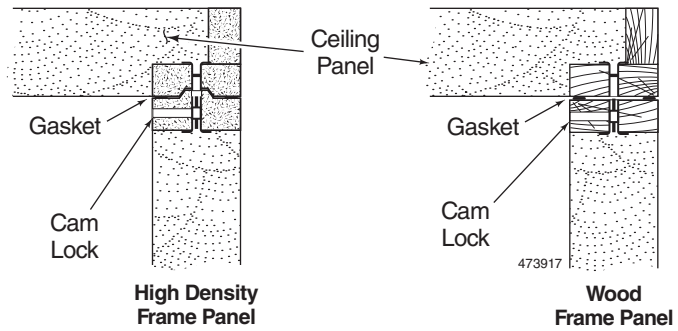

Figure 27. Cam Lock Ceilings

## Doors and Other Add-On Items

Doors must be attached square and solid in their openings.

### Swing Doors with Flat Frames

Standard swing doors provided with Walk-Ins generally come in a panel frame that installs similar to wall panels. Oversized doors or replacement doors may come with flat frames. Refer to the Swing Doors Installation Manual for more information.

See Figure 28.

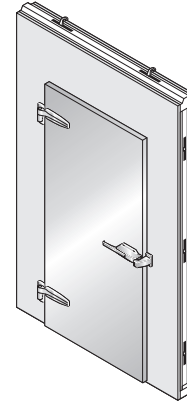

Figure 28. Swing Doors



**CAUTION:** Always make sure that flat frames are fastened into panels equipped with backing (see Shop Prints). If the panels do not have backing, double frames are required.

### Horizontal Sliding Doors

Horizontal sliding doors are available in single sliding or bi-parting configuration. They can be operated manually or electrically. These doors come with flat frames. Refer to the appropriate Horizontal Sliding Doors Installation Manual for more information. See Figure 29.



**CAUTION:** Make sure that flat frames are fastened into panels equipped with backing (see Shop Prints). If the panels do not have backing, double frames are required.

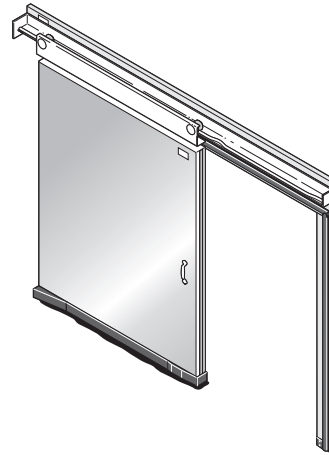

Figure 29. Sliding Doors

### Vertical Lift Doors

Vertical Lift Doors are available as plain slab or sectional doors and can be operated manually or electrically.

Refer to the Vertical Lift Doors Installation Manual for more information. See Figure 30.



**Warning:** Vertical Lift Doors must be installed by a licensed professional overhead door technician.



**Caution:** Make sure that flat frames are fastened into panels equipped with backing (see Shop Prints). If the panels do not have backing, double frames are required.

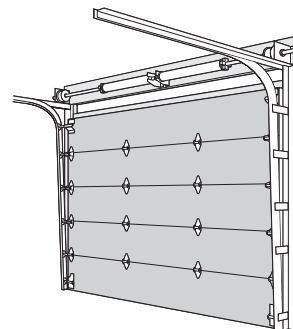

Figure 30. Vertical Lift Doors

## Traffic Doors

**Double-Acting Doors** – Normally come without frames. Refer to the appropriate Traffic Door Installation Manual for more information.

See Figure 31.

**Strip Curtains** – Attach to the interior side of a wall panel, above the opening. If space above the opening is limited, the strip curtain may be attached to the ceiling. Backing inside the panels is required. If backing is not present, use carriage bolts, or similar fasteners, to bolt through the panel.

**Flexible Doors** – Attach to the interior side of a wall panel, alongside of the opening. Backing inside the panels is required. If backing is not present, use carriage bolts, or similar fasteners, to bolt through the wall panel. See Figure 31.

## Glass Doors and Windows

Glass doors and windows install in dedicated openings. If the glass doors or windows are not provided by Imperial Brown, make sure the opening size indicated on the Shop Print matches that required for the glass doors you have purchased.

See Figure 32.

## Shelving

A shelving system, if included, can be either free standing or cantilever. Cantilever shelving requires backing in the wall panels. Consult the Shop Prints to determine where the backing is located.

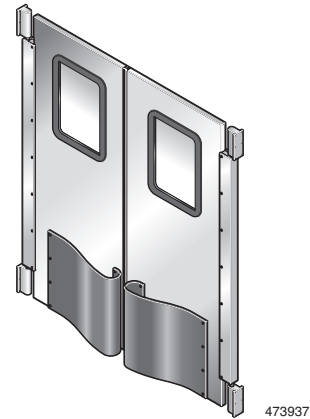

Figure 31. Double-Acting Traffic Door

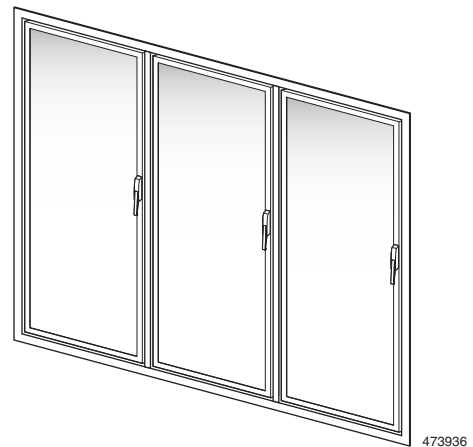

Figure 32. Glass Doors and Windows

## Finish Work

### Snap Caps

Place 1/2" buttons, called snap-caps, into cam lock holes. Snap caps are colored to match the metal finish (white or grey plastic). Floor snap caps are metallic.

### Tie-Downs and Cove Base

If the Walk-In is equipped with tie-downs and/or cove base, install them at the floor and ceiling areas as indicated in the Shop Prints. Pay attention to the amount of ceiling tie-down overlap.

### Door Angles

Door angles are used to stabilize door jambs. Door angles may not be necessary when floor tie-downs are provided. Check the Shop Prints to see if they are specified.

Align the door frame with adjacent wall panels, making sure the opening is square and the frame is plumb, before installing the door angles. *See Figure 33.*

### Thermometers

Thermometer probes are typically attached to the door jambs. Once walk-in installation is complete, please move probes away from openings.

### Wainscoting

Install wainscoting as indicated on the Shop Prints. Be certain to align the top of the wainscoting with the top of the kick plate on the door, if so equipped.

Typically wainscoting does not touch at the wall corners. In order to space the wainscoting evenly, do a preliminary layout before fastening the plates.

### Finish Caulk

A small amount of silicone caulk (matching panel color) is supplied to seal joints. Apply at the interior of the wall to the floor joint at a rate of 1 tube per 30 linear feet. All exposed seam without gasket must be sealed with caulk.

### Ceiling Trim

Ceiling panels with unfinished ends may require the installation of ceiling trim (also referred to as ceiling caps). *See Figure 34.*

**Note:** Walk-Ins equipped with roofing material or ceiling closure might not include any ceiling trim.

## Miscellaneous

### Digital Alarms

Digital alarms may require to be programmed to operate per user requirements. Please refer to corresponding device installation and operation manual.

### External Ceiling Support/Internal Beam Support

For ceiling support and/or internal beam support information, please reference shop prints that pertain to your specific installation project for guidance. Details are provided in the drawings.

### Other Devices

Please check devices' installation and operation manual.

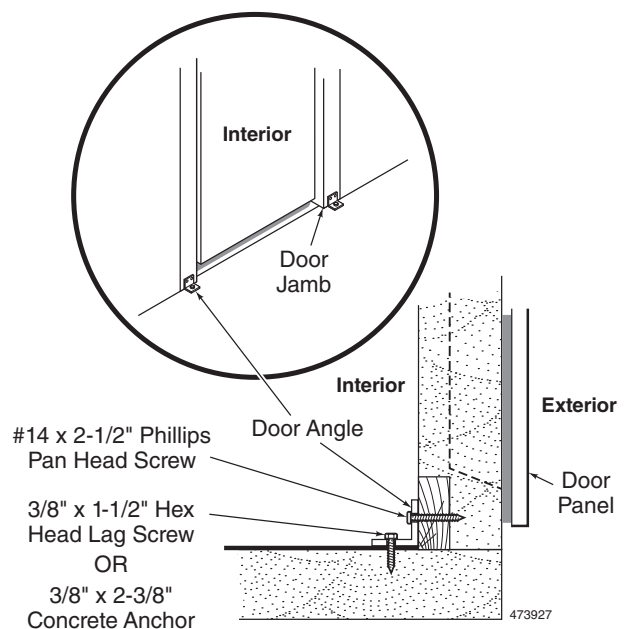

Figure 33. Installing Door Angles

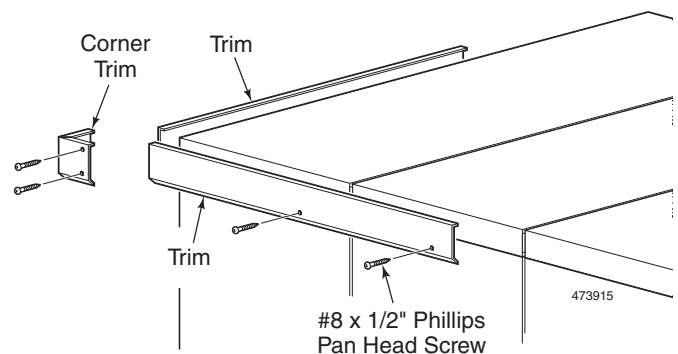

Figure 34. Ceiling Trim

## Refrigeration Installation

This section applies to refrigeration systems supplied by Imperial Brown, Inc.

### General

- Walk-In and/or refrigeration Contractor shall follow all directions given in the present manual and in the refrigeration manufacturer Installation and Operation Manual
- Installation of Walk-In and Refrigeration must meet all local and state building all mechanical codes.
- Installers to provide Walk-In and Mechanical permits as required.

### Scope of Work

- Note any freight damage on Bill of Lading in condensing units and evaporator crates.
- Uncrate and dispose of packaging.
- Hang evaporators.

**NOTE:** TXVs, solenoid and thermostat are provided.

- Set condensing units on pads or curbs provided by others. Provide crane if needed for roof lift.
- Install interconnecting pipe, of the correct line size, properly insulated.
- Connect condensing unit and evaporator electrical to service provided.
- Install condensate drain lines. Include heat trace and insulation on low temperature coolers and freezers.
- Leak test, evacuate, charge and start systems per install instructions and ASHRAE standards.
- Complete Service Record and submit to Imperial Brown installation department.

**NOTE:** During store set-up and stocking, defrost demand will be very high because green concrete, opened doors to outside ambient, opened cooler and freezer doors for stocking, initial pull down of beverages, etc. Refrigeration contractor to make return visit after set-up and stocking to make certain all defrosts are operational and keeping coils clear.

### Defrost configuration:

- Air defrost on coolers, initial startup setting 4 @ 45 to 60 minutes.
- Electric defrost on freezers, initial startup setting 4 @ 15 to 20 minutes.

**NOTE:** Smart Defrost (on-demand defrost on low-temperature coolers and freezers may be provided. Proper installation and set-up required per manufacturer installation manual.

### Installing Refrigeration Indoors

All condensing units (split or self-contained) installed inside of the conditioned space commonly located on top of the walk in cooler or freezer must have enough area/ventilation to dissipate the calculated THR (Total Heat of Rejection) generated from the condensing unit. If a higher ambient temperature is introduced to the condensing unit, the refrigeration system's cooling capacity will be reduced and the refrigeration system may not operate as originally designed.

### Refrigeration Contractor

A contractual arrangement with an experienced and licensed Refrigeration Contractor is strongly recommended for all refrigeration systems including Self-Contained and Factory Installed Quick Connects. An experienced and licensed Refrigeration Contractor can support and guide the process. This service includes necessary refrigeration adjustments to the defrost timer and to the TXV maximizing refrigeration system thermal efficiency specific to the application.

**NOTE:** Any excess of refrigeration lines on a refrigeration system with factory mounted Quick Connect must be stored properly to avoid oil traps. Please refer to the refrigeration manufacturer's I&O manual for further details.

### (HOT TROUBLE TIP) For Beacon II and Quick Response Controller Systems

For 208-230V applications, please ensure that the low voltage transformer is correctly set to match the field supplied voltage to the Evaporator. To confirm this setting, test the control voltage between terminals COM and 24 ensuring your control voltage is greater than 24V.

## PERIODIC MAINTENANCE

Perform the following tasks on a regular basis (frequency determined by the operating conditions at the installation site).

### Cleaning

Proper cleaning and upkeep is important. Basic procedures of cleaning and preventive maintenance will ensure many years of quality service.

Keep floor surfaces clean of any liquid or solid.



**WARNING:** Floors may become slippery and hazardous when wet, greasy or icy. Keep floor clean and free from moisture or ice buildup.

Wipe spills with warm water and mild detergents, rinsing thoroughly with hot water. Avoid using excessive water.



**CAUTION:** Never use caustic or abrasive cleaners. Check with manufacturer for potential cleaning product reaction with different metals and finishes.

Never use high-pressure cleaning equipment. Panel seals may be damaged.

Dry thoroughly to prevent ice formation.

Use same procedure as above to remove dirt or fingerprints from wall surfaces.

**NOTE:** If finish is stainless steel, wipe in the direction of the metal “grain.”

Clean door gaskets and sweep regularly with mild soap and water to remove grease and oil.

### Preventive Maintenance

- Lubricate door hinge pivots, latches and inside releases with petroleum jelly at least once a year.
- Adjust door sweep as necessary to compensate for wear or uneven floors.
- Periodically check all hardware and fasteners (attaching screws) to be sure that they are firmly anchored. If loose, tighten. If any hardware malfunctions, see owner’s manual or contact the manufacturer.
- Maintain unrestricted air flow across the evaporator unit(s) and be sure the evaporator coil is kept free of dirt at the inlet and outlet. Check that the evaporator unit drain lines run free and clear.

### Tips

- Do not place fresh product (fruit, produce, exposed foods) in the direct path of the cooled air. This may cause premature drying, add excess moisture to the air, and shorten the product’s shelf life.
- Place product on shelves to allow complete air circulation around each vessel. Stacking product in front of the coil may inhibit cooling and proper operation by obstructing airflow.
- Close the door behind you. The door is equipped with an inside release handle. An open door builds excess humidity and works against the refrigeration system.

## TROUBLESHOOTING

### Doors

Ice formation or water condensation around the freezer door may indicate a defective heat cable or poor gasket seal. If the gasket is not sealing properly, check the door alignment and make sure that the hinges and latch/strike are adjusted properly. Check for proper and constant power source to the heat cable (check that the circuit breaker is on). If the door appears to be correctly adjusted and the power is on but the problem is not resolved, please call our customer service hot-line for assistance.



**CAUTION:** Freezer doors are equipped with heater cables. These elements should not be turned on unless the temperature reaches freezing or below. Otherwise, the element could become too hot and/or damaged.

If the doors in a freezer are difficult to open, check that the relief air vent is functioning properly. Check to see if the air vent is frozen closed. De-ice the air vent and make sure that its heat cable is working. If not, check that it is connected to a constant power source. If the air vent heat cable is found to be defective, replace the air vent.

For electric sliding doors, please refer to the Sliding Door Installation Manual.

### Refrigeration Equipment

Refer to the refrigeration equipment manufacturer's troubleshooting guide before attempting any repairs.

When beginning any problem diagnosis, pay attention to the following:

- If ice is forming on the ceiling near the evaporator unit, or if the evaporator unit is icing too much, there might be a problem with the refrigeration system. Please contact your refrigeration service company.
- If water drips from the evaporator unit inside the Walk-In, the evaporator unit drain line might be plugged. If so, clean the drain pan and its pipe. In a freezer, check that the drain line heater is working and is connected to a constant power source.

# Imperial Brown, Inc.

## Urethane Insulated Panels WARRANTY

**Imperial Brown, Inc.** warrants to the original purchaser of its products that the foamed-in-place urethane panels purchased from Imperial Brown, Inc. are free from defects in material and workmanship for a period of fifteen (15) years from the date of original shipment under normal use and service.

### Exclusive Warranty - No Implied Warranties

This written and expressed warranty is the only warranty provided by Imperial Brown, Inc. on the products it sells. All warranties, which might otherwise be implied in this contract, are hereby excluded from this contract. This includes excluding the implied warrant of merchantability and fitness for a particular purpose. There are no warranties, which extend beyond the description of the warranties on the face hereof.

### Exclusive Remedies

The buyer's exclusive remedy under this warranty or for the breach of this warranty shall be the repair or the replacement of the defective part by Imperial Brown, Inc. Imperial Brown, Inc. shall repair, or at its option replace, F.O.B. the factory, any part of the product which its examination shall disclose, to its satisfaction, to be defective. No other remedy, including rejection of goods, revocation of acceptance, nor consequential damages for personal or property damage, nor incidental damages shall be allowed to the buyer of this product.

### Hardware, Electrical Components and Accessories

All hardware, electrical components and accessories are warranted to be free of defects in materials and workmanship under normal use and service for one (1) year from the date of original shipment. Service items, such as fluorescent lights, ballasts and starters are not covered by this warranty.

### Refrigeration Equipment

The refrigeration equipment is not covered by this warranty. Imperial Brown, Inc. does not expressly or implicitly warrant the refrigeration equipment to be free of defects. All implied warranties of merchantability or fitness for a particular purpose are excluded by Imperial Brown, Inc. for the sale of refrigeration equipment. The buyer's exclusive remedy for defects in refrigeration equipment is the warranty provided by the manufacturer of that equipment. An extended (4) year compressor warranty is available for purchase from the manufacturer or Imperial Brown.

### Voidability of Warranty

This warranty is void and of no force or effect, and the buyer shall have no expressed or implied warranties against defects, nor remedies for defects, if any of the following events occur:

- The panels are not installed within 120 days of original shipment
- The panels are not installed by a factory authorized installer
- The user exceeds the floor's weight limitations, as established by the design specifications
- The panels have been subjected to improper installation, misuse, abuse, neglect, alteration, accident, fire, flood, earthquake or other natural disasters.

This warranty does not include food or product loss, labor or transportation charges for replacement or repair of defective parts. This warranty is nontransferable. The original purchaser is the firm or individual to whom Imperial Brown, Inc. originally sold this product.

\*Imperial Brown panels are designed to operate within the following temperature ranges:

Interior Freezer: -20 degrees F. to 32 degrees F.

Interior Cooler: 33 degrees F. to 100 degrees F.

WE MUST BE NOTIFIED UPON PLACEMENT OF THE ORDER IF OPERATING TEMPERATURES ARE OUTSIDE THE ABOVE NORMAL DESIGN TEMPERATURES TO PROPERLY DESIGN THE PRODUCT OR THE WARRANTY MAY BE VOIDED.

#### West Coast Facility

2271 NE 194th Avenue • Portland, OR 97230  
Toll Free (800) 238-4093 • Local (503) 665-5539  
Fax (503) 665-2929

#### Midwest Facility

2015 W. Main St. • Prague, Oklahoma 74864  
Toll Free (800) 289-2784 • Local (405) 567-1960

#### East Coast Facility

209 Long Meadow Drive • Salisbury, NC 28147  
Toll Free (800) 438-2316 • Local (704) 636-5131  
Fax (704) 216-2758



For the latest manuals and resources, just  
snap on the QR Code, or visit  
[www.imperial-brown.com](http://www.imperial-brown.com)

